

## CHAPTER II

### LITERATURE REVIEW

#### 2.1 Broiler Chicken (*Gallus gallus domesticus*)

A broiler chicken is a type of chicken bred and raised specifically for their meat. The broiler chickens grow much quickly and become larger than laying or any other traditional dual purpose breeds (Figure 2.1). They are distinguished for having excellent feed conversion ratio, low levels of activity, and fast growth rates reaching market weight of 1.8-2.3 kg within 5-6 weeks (Beutler, 2007).



**Figure 2.1:** The Commercial Broiler Chicken

## 2.2 Malaysian Native Chicken

The Native chicken, known in Malaysia as village chicken or “Ayam Kampung”, is an important breed distributed in Malaysia Peninsular and some parts of Indonesia and Thailand. The Malaysian native chickens (Figure 2.2) are diverse population that resulted from uncontrolled crossbreeding of the Red jungle fowl (indigenous Southeast Asian chickens) and mixed European exotic domestic breeds, mainly the British (Kadhim et al. 2014).



**Figure 2.2:** Malaysian native chicken used in this study

They are dual-purpose birds that are reared by most rural households and serve as an important source of meat and eggs (Khor & Sharif, 2003; Diwyanto & Iskandar 1999).

They are known as slow-growing birds that take over 4 months to reach market weight of between 1.1 and 1.5 kg and the females produce about 100 eggs/year (Azahan

1994); therefore they have lower productivity and a longer production cycle than that of the improved breeds (Diwyanto & Iskandar, 1999; Lokman et al., 2015). The main differences between native and broiler chickens are summarized in Table 2.1.

**Table 2.1:** The main differences between Malaysian Native and Broiler Chickens

	<b>Native Chicken</b>	<b>Broiler Chicken</b>
Breed	Crossbreeding of red jungle fowl and mixed Europeans domestic breeds	Gallus gallus domestics
Market weight	1.1 - 1.5 kg	1.8-2.3 kg
Market age	Over 4 months	5-6 weeks
Activity	High levels of activity	Low levels of activity
Rearing systems	Extensive and relatively higher resistance to diseases	Intensive and relatively higher sensitive to diseases

As the Malaysian native chickens are crossbred, their physical characteristics and plumage colours are variable among the population (Azahan 1994). The most common is the black-red variety which has been selected for this study.

### 2.3 Meat Quality and Consumption Survey

Meat quality has a major impact on consumer satisfaction, which turns to be an important issue in meat industry. In order to meet the demand for high quality meat, the meat industry should consistently produce and supply meat that is healthy, tasty, and safe for the consumer to ensure continued consumption of meat products (Dalle Zotte, 2002).

Analyses by Food and Agricultural Organization of the United Nations (FAO) had shown a significant increase in the meat consumption over time on a global basis. A trend is about 60% between 1990 and 2009, from 175,665 thousand tons to 278,863

thousand tons as seen in Table 2.2. This increase in aggregate meat consumption is partly due to increasing population (Popkin & Gordon-Larsen, 2004).

However, global consumption per capita raised by nearly 25% from 33.7 to 41.9 kg per capita. This suggests other factors that are responsible for a growing demand which may be most likely due to the improvement of living standards in many developing countries. Although these data are likely to over-estimate meat consumption, they have been widely used as guidance for agricultural and food strategies (Goldewijk, 2001).

**Table 2.2:** Global Meat Consumption from 1990 to 2009 (in 1000 tons).

Meat Type	1990	2009	%
Beef	54065	63835	18.1
Mutton and Chevon	9100	12762	40.2
Pork	68692	105503	53.6
Poultry Meat	40173	90664	125.7
Other Meats	3634	6098	67.8
Aggregate	175665	278863	58.7

Source: FAO (2014).

The Malaysian meat industry is basically dominated by the poultry meat which supplies more than 80% of the total meat consumption of the country. Malaysia has one of the highest per capita consumption of chicken in the world, with about 35 kg per capita recorded in 2010 (DVS, 2011; Jayaraman et al., 2013). The consumption of chicken meat is the highest in Malaysia among other sources of meat, mostly because of its healthy and tasty image and also because it is the cheapest source of protein and there are no religious prohibitions for eating. The Malaysian consumers are very

sensitive towards issues related to meat quality and food safety, while the majority of the Muslim consumers are aware about the halal food and they will not accept products that are not labeled halal by the Department of Islamic Development Malaysia (JAKIM) (Hasnah, 2011). In this respect chicken meat is particularly beneficial and may have nutritional advantages as a result of its consumption compared to other animal products.

On the other hand, native chickens play an important role in village and rural areas as dual-purpose chickens that needed to meet the household's socio-economic (Diwyanto & Iskandar 1999). Although the growth performance of native chickens is inferior to that of broiler chickens, they are known to adapt well to extensive rearing systems with relatively higher resistance to diseases (Azahan 1994). From the consumer-preference viewpoint, native chicken meat is likely to have acquired popularity among domestic consumers due to its preferable taste and also as a source of high quality protein and vitamins that provided in nutrition (Jaturasitha et al., 2008; Chipondeni, 2015). Furthermore, native chickens may have nutritional advantages over the conventional broilers and therefore they have a positive nutritional and economic impact in most efficient and cost-effective way (Chipondeni, 2015). Considering biodiversity and conservation of poultry, the native chickens are essential part of the genetic diversity that comprises indigenous poultry (Delany, 2003). This diversity is needed for future advances and improvement in case of changing environments and/or consumer demands (Yousif, 2015).

#### **2.4 Meat Quality Attributes of Chicken Meat**

Meat quality can be described as the qualitative characteristics that make up the meat. These include physical, chemical, nutritional, microbial, biochemical, sensory and

cooking properties of the meat. Physical attributes such as appearance (colour), texture, juiciness, tenderness, odour and flavour are mostly used by consumers to determine the quality of the meat prior or after purchase but a processor is more concerned about the shelf life, cook loss, drip loss, pH, shear force, water holding capacity, protein solubility and fat content of the meat (Allen., 2001). All these attributes are essential in order to reduce downgrading of the meat product. Grading of poultry product is usually based on the physical attributes without considering the functional properties of the meat which is the bases for further processing of meat by food and meat industries (Barbut, 1996). pH, colour, water holding capacity and tenderness are the major quality parameters usually used to assess meat quality (Dadgar et al., 2010).

#### **2.4.1 Meat pH**

Meat pH is the most important factor responsible for meat quality and protein functionality. Meat pH is associated with numerous other meat quality attributes such as color, water-holding capacity WHC, tenderness, juiciness and microbial stability (shelf-life) due to its effect on protein structure and hydration properties (Cheng, 2008). Meat quality variation among chicken populations is caused by the initial rate of pH decline after slaughter and the ultimate pH ( $pH_u$ ) of meat reached at 5-6 hours post-mortem. A strong relationship between  $pH_u$  and lightness ( $L^*$  value) of the breast meat in chicken has been reported (Dadgar, (2010). In addition, drip loss, water-holding capacity and cooking yield of raw meat are strongly linked and correlated with  $pH_u$  and  $L^*$  (Le Bihan-Duval et al., 2001; Debut et al., 2003). Solubility and water binding capacity are minimal with a drop in pH of meat to the isoelectric point (where the positive and negative charges are equal on proteins) and this is due to the

fact that there is no net charge on the proteins to bind to water molecules and also there is no enough space for water within the myofibrils due to increased affinity within myofibrils (Zayas, 1997). In contrast, high ultimate pH produces a dark, firm and dry (DFD) meat with high WHC, poor storage quality due to high moisture content and a faster rate of production of off-odours and an accelerated microbial growth (Allen et al., 1998; Le Bihan-Duval, 2004). On the other hand, a fast drop in pH post-mortem and low final pH results in pale, soft and exudative meat (PSE defect) although with better tenderness and reduced WHC (Dadgar, (2010).

#### 2.4.2 Meat Colour

Meat colour is also an important meat quality parameter that determines the overall acceptability and purchase decision by consumers. Most consumers attributes meat colour to freshness and overall quality. Poultry meat shows a remarkable difference in colour due to its muscle biochemistry and histology. Poultry are categorized as either white or dark meat. Evaluation of colour can be done using different systems, the most common are CIE LAB and Hunter L, a, b solids scale. In the CIE LAB system, the lightness of the surface is expressed by L\* value and is ranging from 0-100 (black to white), meat redness a\* is ranging from negative to positive (green to red), and yellowness (b\*) value ranging from negative to positive which stands for blue to yellow (Barbut, 2002). It has been reported that meat lightness increases significantly over post-mortem time hence the time at which L\* value is measured could affect reading values of L\* (McCurdy et al., 1996).

The noticeable difference in the colour of meat is a result of myoglobin pigment concentration. Anadon (2002) reported that changes in breast meat colour is more

pronounced which is as a result of its natural light colour and because it makes up a large percentage of the carcass.

Meat colour differs based on the myoglobin and haemoglobin concentration (major meat colour pigments), chemical state of pigments, light reflection off the meat (Froning, 2002). Haemoglobin is found in the red blood cells and its concentration in meat is dependent on the efficiency of bleeding during slaughtering process (Swatland, 1994). Myoglobin is a soluble protein formed from a single polypeptide chain, which is surrounded by an oxygen-carrying heme group composed of an atom of iron and a porphyrin ring. The myoglobin functions primarily for the transportation of oxygen within the muscle fibre (Swatland, 1994). Factors such as age, sex, species and genotype can affect the concentration of myoglobin (Barbut, 2002). Meat colour, fibre content and myoglobin content are highly correlated with basic differences in meat colour due to relative amounts of white and red fibres. In addition, pH and post-mortem temperature play important roles on the extent of protein denaturation and physical appearance of meat (Lawrie, 1998). The denaturation of protein is proportional to light scattering from a muscle surface. The minimal of protein denaturation at  $\text{pH} \geq 6.0$  and water molecules are tightly bound causing more light to be absorbed by the muscle and hence, the meat appears translucent in colour. In contrast, higher protein denaturation at  $\text{pH} \leq 6.0$  is causing an increase in light scattering and making the muscles darker. Lightness ( $L^*$ ) is affected by light scattering but has little effects on meat redness ( $a^*$ ) and yellowness ( $b^*$ ) (Barbut, 1997; Swatland, 1994).

Meat colour has been reported to relate to other meat quality parameters and functional properties of meat (Barbut, 1997; Qiao et al., 2001). The breast meat

quality can be measured by using  $L^*$  indicator. Dark broiler breast fillets shown to have lower  $L^*$  values, higher redness values ( $a^*$ ) and lower yellowness values ( $b^*$ ) compared to light broiler breast fillets (Allen et al., 1997; Barbut et al., 2005). Breast meat with variety of lightness ( $L^*$ ) has been reported with wide variation in  $L^*$  values. The differences are due to the wide scattering of muscle pH values at post-mortem (Barbut 1997; Petracci et al. 2004). Factors such as genetics, age, sex, flock, nutrition, season of the year affects the lightness value ( $L^*$ ) of meat.

### 2.4.3 Water Holding Capacity

Water holding capacity is a significant quality trait that determines both consumer's satisfaction and meat processors. The ability of meat to hold water helps with tenderness, juiciness, firmness and appearance of the meat and ultimately impact meat quality. WHC of meat is classified as the water binding potential (WBP), expressible moisture and free drip. WBP is the ability of the muscle proteins to retain excess water under external forces (Swatland, 1994). Expressible moisture indicates the amount of water separated from the meat by the use of force, while free drip represents the amount of water lost freely from the meat as a result of gravity (Swatland, 1994) which is important for consumer acceptability and retail display of tray packed meat.

As reported by Offer & Knight (1988), about 88-95% of water in the muscle is held within intracellular spaces between actin and myosin filaments, and about 5-12% is located within the myofibrils. Several factors are also reported influencing WHC, such as pH, sarcomere length, ionic strength, osmotic pressure and development of rigor mortis. After animal death, lactic acid production and pH decline causes the reduction in water binding ability of the meat due to changes in protein postmortem (e.g. denaturation, loss of protein solubility) causing the reduction in the availability to

holding water in muscle protein (Offer & Knight 1988). As muscle fibres deplete all their adenosine triphosphate (ATP), the membranes no longer confine the cell water and fluid is lost from the muscle fibre that may contribute to the exudate lost from the meat (Swatland, 1994).

## 2.5 Skeletal Muscle Structure

A single muscle contains around 1000 muscle fibers running the whole length of the muscle and joined together at the tendons (Swatland, 1994). Typically a muscle spans a joint and is attached to bones by tendons at both ends. One of the bones remains relatively fixed or stable while the other end moves as a result of muscle contraction (Berchtold et al., 2000). Skeletal muscle cells (fibers) are multinucleated containing a range of quantities of components such as mitochondria, ribosomes, soluble protein, glycogen and lipids (Monti et al., 1999; Ouali, 1992). As illustrated in Figure 2.3 the connective tissue acts as coverings which support and protect the subtle cells to withstand contraction forces and also allow for passage of blood vessels and nerves (Coulis & Ouali, 2002). Skeletal muscle has an abundant supply of blood vessels and nerves which are vital for skeletal muscle contraction (Karlsson et al., 1999).

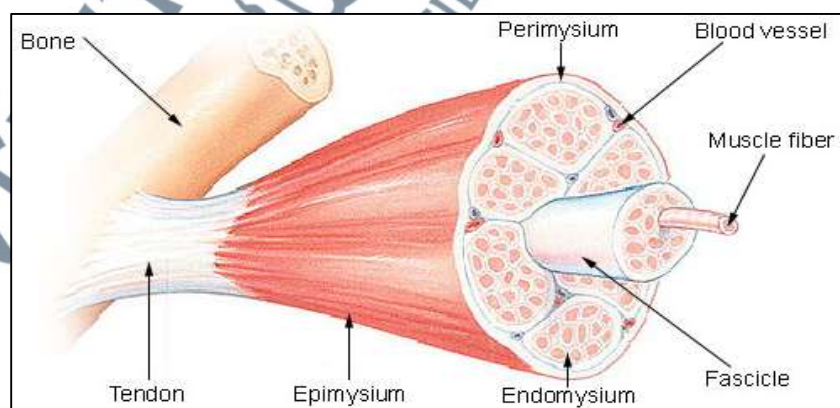
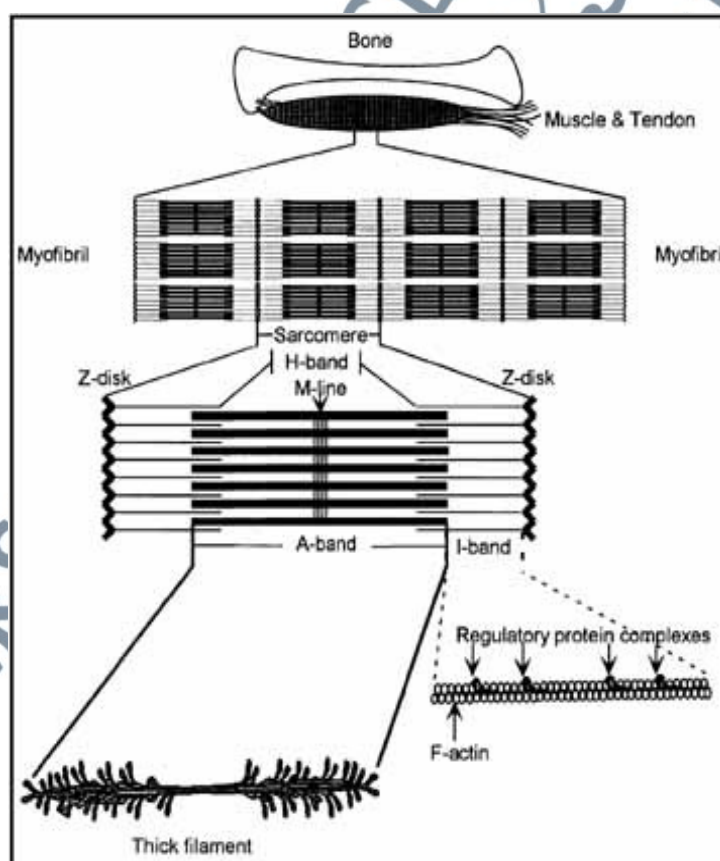

**Figure 2.3:** The structure of skeletal muscles, a cross-sectional model

Source: <http://people.eku.edu>

## 2.6 Sarcomere

Study the sarcomere architecture is important to understand the contractile unit and its relation to muscle growth and meat development or tenderness. The sarcomere is smallest unit contractile in the myofibril (Ouali, 1992). Under the light microscope, muscle tissue shows a typical alternating banding pattern of light and dark bands (Figure 2.4). The dark A-bands (A = anisotropic) consist of the thick or myosin filaments with on both sides some overlap of the thin filaments. The light colored I-bands (I = isotropic) consist of thin or actin filaments on both sides of a thin but distinct Z-line. These two filaments are linked inside two adjacent Z-disks, which extend from the thick filaments (Karlsson et al., 1999; Coulis & Ouali, 2002).



**Figure 2.4:** Biochemical components and microscopic structure of muscle tissue.

Source: <http://meat.tamu.edu>

The degree of consistency and arrangement of the filaments may significantly influence meat tenderness. The disturbance in the I-band postmortem can also contribute to the tenderness of meat. However it is believed that enzymatic degradation of proteins in the Z-band has the most significant role in meat tenderness. The calcium activated calpain system, including lysosomal cathepsins and the multi-catalytic proteinase complex, has an important role for the proteolysis of the I-band.

## **2.7 Conversion of muscle to meat**

The overall mechanical and biochemical changes of the muscle after the process of slaughtering largely determines the final meat quality. The development of rigor mortis is important to allow for the conversion of muscle to meat and hence, important for proper meat quality (Sams, 1999). After exsanguination, the muscle cells continue to respire, producing and consuming energy in the form of ATP. As the remaining oxygen left in the carcass is used up, the cells produce the needed ATP anaerobically. Glycolysis is an important biochemical process in the post-mortem conversion of muscle to meat. It involves the breakdown of glycogen to glucose 6-phosphate (G6P), glucose and lactic acid using the anaerobic respiration in order to produce ATP. The ATP produced is used for muscle metabolism after killing the animal (Hartschuh et al., 2002). As blood circulation hinders the removal of the accumulated lactic acid in the system, intracellular pH drops to a level that hinders further glycolysis and hence a stop to ATP production. As the ATP level drops to about 0.1mmol/g, rigor mortis is developed (Sams, 1999).

The process of muscle conversion to meat is completed when all the energy reserves in the muscles have been used up. The length of time required before rigor mortis can occur depending on the amount of glycogen available within the muscle at the time of

exsanguination and the continued activity of glycolytic enzymes (Swatland, 1994). Rigor mortis sets in when all the energy in the muscle has been expended and a temporary toughening of the muscle is noticed. Rigor mortis is not an instant process; it begins at a certain time after slaughter because of the gradual depletion of glycogen. This lag time is called the delay phase (Lyon & Buhr, 1999; Barbut, 2002). It has been reported that rigor in breast meat can occur within 15 minutes post-mortem, whereas it takes leg muscle about 3 minutes to come into rigor. However, full rigor occurs at 2-4 hours post-mortem in breast fillet compared to less than 2 hours in leg meat (Kijowski et al., 1982). The muscle at this time is inextensible but after a certain period of time, the muscle begins to relax again as a result of the breakage of sarcomere components which is due to the activity of proteolytic enzymes. Some of the major changes during the aging process include the degradation of the thin protein band which actin filaments are attached in a striated muscle fibre (Z-line) and degradation of the protein nebulin, titin and desmin. The major proteolytic enzymes calpains and cathepsin are calcium dependent and this calcium is released from the sarcoplasmic reticulum and mitochondria during the process of post-mortem aging (Kijowski et al., 1982).

## **2.8 Factors Contributing to Tenderness**

### **2.8.1 Collagen**

Collagen is most commonly found in the skin, bones and connective tissue, making up from 25 % to 35 % of the whole-body protein content, therefore, it is providing structural support, strength and a degree of elasticity. There is a relationship between collagen and toughness, as it can be resistant to physical breakdown during cooking. Collagen molecules are bound together through intermolecular crosslinks that providing structure and strength. Crosslinks are less soluble, and thermally stable

when the initially reducible crosslinks are replaced with mature crosslinks (Cooke & Wien 1971). The proportion of mature to reducible crosslinks increases with age, resulting in older animals that often have less tender meat than younger animals.

### **2.8.2 Muscle shortening, cold shortening and sarcomere length**

When muscle entered rigor outside a temperature range of 14 to 19°C, the muscle should shorten at lower temperatures. Proteins myosin and actin in the contractile muscle will be shortened due to muscle contraction leading to shorter sarcomere length. When applied higher temperature or cooking, the shortened muscles will be tough suggesting that sarcomere length has an important effect on tenderness. Many experiments have been subsequently conducted to examine the relationship between sarcomere length and shear force and indicator of tenderness (Offer & Knight 1988). Longer sarcomere lengths of muscle contributed to lower shear force values compared to shorter sarcomere lengths (Barbut, 2002)

Rapid cooling process after slaughter leads to severe muscle shortening in carcasses meat. This condition is involving cooling muscle temperature below 10°C. In the process a muscle is contracted in the pre-rigor state with high concentration of calcium ion causing activation of the myosin ATPase. The cold temperatures reduce the efficiency of the calcium pumps needed to pump calcium out of the muscle cell into the sarcoplasmic reticulum (Young, 2012). At a temperature well above 20°C, muscle may also undergo 'heat shortening' or 'rigor shortening'. High temperatures are likely to speed up the glycolytic rate because of enhanced action of glycolytic enzymes contributing to increased rate of pH decline. Interaction between faster pH decline and higher temperature contribute to the shortening conditions. Rigor

shortening contributes to muscle being tough that is resulted from isometric tension and diminished proteolytic enzyme activities (Kazeem, 2014).

### **2.8.3 Intramuscular fat**

Intramuscular fat is located in adipose cells that along with connective tissue comprise the endomysium and perimysium that cover muscle fibers and bundles of muscle fibers. Intramuscular fat (marbling) is considered as one of the main quality attributes of meat (Young, 2012). However, intramuscular fat plays a determinate role in providing flavour and juiciness that may extend to meat tenderness development (Young, 2012). Many studies have proposed that meat containing high quantities of fat tend to be tenderer (Young, 2012).

In general, fat is made up of triglycerides that stay within adipose cells. These fats have lubricating effect while meat is chewed, making chewing easier as muscle fibers and bundles slip past one another (Young, 2012). Moreover, intramuscular fat acts as insulator towards heat-induced toughening resulting from cooking. However, high quantities of fat within muscle provide a resistant layer that diminishes the heat transfer throughout the muscle. Collectively meats containing a high quantity of fat will tend to be 'undercooked' resulting in more tender meat (Grandin, 2007).

### **2.8.4 Muscle pH and meat tenderness**

During the transformation of muscle to meat pH is related to biochemical processes. The glycolytic cycle starts immediately after slaughter in the muscle tissue, in which glycogen, the main energy supplier to the muscle, is broken down to lactic acid. The build-up of lactic acid in the muscle produces an increase in its acidity, as measured by the pH. In a normal animal, after slaughtering during 24 hours the ultimate pH falls

to around pH 5.8-5.4 (Barbut, 2014). At the isoelectric point, thick and thin filaments in myofibrils move closer together and reduce the water space between them. Thus, as the pH declines post mortem, filaments move closer together, myofibrils shrink and the volume of sarcoplasm increases. Eventually, muscle fibres depleted all their ATP, their membranes no longer confine the cell water, and fluid is lost from the muscle fibre and may contribute to exudate lost from the meat (Locker, 1963). Extracellular space in muscle is greatly increased after short periods of muscle activity caused by ante mortem extracellular fluid unknown as a meat exudate. Exudate-filled spaces between muscle fibre bundles contribute to the soft texture and easily separated fibre bundles in PSE muscle because the amount of water bound within muscle fibres may have an effect on meat tenderness. X-ray diffraction results indicate that the detachment of myosin molecule heads may contribute to the softness of PSE pork (Barbut, 2014).

### **2.8.5 Proteolysis**

The activities of the hydrolyzed, proteolytic enzymes play a significant role in breaking down structural myofibrillar and cytoskeletal proteins leading to the development of meat and tenderness (Barbut, 2002). The enzymatic degradation of proteins is reported occurs at the Z-band and the proteolysis of the I-band (Figure 2.4). These activated enzymes include inter-myofibrillar (desmin), intra-myofibrillar (titin and nebulin), and proteins that link proteins to sarcolemma and cell membrane (Koochmaraie, 1992). Titin and desmin are considered key factors in the development and tenderization of meat. The activities of these proteolytic systems can be up to 14 day postmortem in sheep. The calcium activated calpain system, including lysosomal

cathepsins and the multi-catalytic proteinase complex, have been investigated for their possible role in postmortem proteolysis and tenderization (Koochmaraie, 1992).

## **2.9 Calpain System and Meat Tenderness**

Meat tenderness is determined by specific protein degradation and protein modification which contributed to the disruption of the muscle structure and improves tenderization (Laville et al., 2009; Maltin et al., 2003). Calpain system includes calpain 1 (CAPN1) and calpastatin (CAST) are found to have strong relations with meat tenderness. They are involved in a wide range of physiological processes including muscle growth and differentiation, pathological conditions and post-mortem meat aging. Calpains are calcium-activated proteolysis system with an endogenous activity at neutral pH. The calpain system consists of at least three proteases,  $\mu$ -calpain, m-calpain and skeletal muscle-specific calpain 3, and an inhibitor of  $\mu$ - and m-calpain, calpastatin. It is widely accepted that the  $\mu$ -calpain gene (CAPN1) is a physiological candidate gene for meat tenderness. It requires micro-molar calcium ion concentration to endogenously activate. In postmortem due to the failure of the sarcoplasmic reticulum muscle, the concentration of calcium ion rises from  $10^{-7}$  M to around  $10^{-4}$  M leading to the activity of  $\mu$ -calpain (Vidalenc et al., 1983). However the activity of calpain system is also governed by specific endogenous activity of the calpastatin that act as inhibitor to the protein degradation (Odeh, 2003).

## **2.10 Characterization of Candidate Genes for Meat Quality Traits**

As mentioned above, meat quality traits are very complex, involve many genes and are greatly influenced by environmental factors (Dunner et al., 2013). The appearance and quality require analysis and classification of fat content, composition, tenderness,

water holding capacity, color, oxidative stability and uniformity. They are influenced by breed, genotype, feeding, fasting, pre-slaughter handling, stunning, slaughter methods, chilling, storage conditions and other factors (Rosenvold & Andersen, 2003). The main goal of genome research is to map and characterize trait loci. Unknown numbers of quantitative trait loci (QTL) affect and control the meat quality trait. There are two main strategies used to identify trait loci, association tests using candidate genes and genome scans based on linkage mapping DNA markers. The information of the meat quality trait loci can be applied in breeding programs by using marker-assisted selection (Dunner et al., 2013).

In breeding research of farm animals, single nucleotide polymorphisms (SNPs) are used as genetic markers to track inheritance patterns of chromosomal regions across generations. They are also considered effective tools in the study of genetic factors associated with traits of animal with economic interest (Zhang et al. 2008). Polymorphism markers are crucial in the discovery of new strategies for quantitative trait locus mapping and candidate gene studies (Felício et al., 2013).

## **2.11 Single Nucleotide Polymorphism (SNP)**

### **2.11.1 Definition of SNP**

A single nucleotide polymorphism (SNP) is a nucleotide variation at a specific region in the genome. Typically, SNPs are bi-allelic and by definition found in more than 1 % of the population (Wang et.al., 1998). Although very rarely tri-allelic SNPs are also found in the population with variations less than 1% SNPs. Over 3.1 million human SNPs have been characterized in the international HapMap with SNP density of approximately one per kilobase of DNA (Frazer et al., 2007). The genetic variants can

potentially untangle the molecular foundation of strains and attain insight solutions for functional genomics. SNPs have been broadly used in studies of disease associations for the detection and prediction of human genome diseases. Most pharmacogenomics studies use SNPs to explore the genetic basis of drug response. A wide range of SNP studies for breeding programs have been carried out to predict phenotypic characteristics and their link to the variations of specific SNPs (Mackay et al., 2009)

### **2.11.2 The Way SNPs Impact Different Phenotypes**

The polymorphisms in general are not equally distributed across genomic sequences. They happen much rarely frequent in coding regions rather than in the non-coding. SNPs located in regulatory areas of a gene can change allele specific transcription and transcription rates, and thereby influence function and structure of corresponding proteins. The exonic SNPs in coding regions may be synonymous or non-synonymous. The synonymous substitutions do not change the amino acid in the protein, but that can still alter its function in different way (Chamary et al., 2006) (Kudla et al., 2009). In contrast a non-synonymous substitution alters the primary sequence of amino acid thus changes the produced protein or develops phenotypic differences (Liao et al., 2014). The folding and structure of mRNA could be influenced by SNPs and consequently change the mRNA associated function.

The dissimilar folding of the mRNA coding degrades more rapidly and consequently varying the produced protein, leading to phenotypic variation. Synonymous codon polymorphism may vary protein substitutions, thus producing a protein with a different biological conformation and function. SNPs might also affect mRNA silent substitutions and ultimately produce non-functional protein.

### 2.11.3 Techniques to Identify a SNP

The analyses of SNPs can be performed by mapping and sequencing the nucleotide sequence of a gene and looking for SNPs in the coding regions. Analyzes the associations of SNPs with phenotypic variations are also considered new strategies to monitor allelic specificity and for SNP discovery. DNA fragments amplification by the polymerase chain reaction (PCR) are one the most recognizable techniques to examine efficiency and allelic structure of SNP. This requires designing PCR primers to amplify the target regions of a specific gene. PCR products are sequenced and compared in gene sequences to reveal SNP sites. Although this approach for a SNP discovery allows high level discovery rate, the consisting amplification of DNA fragments are expensive especially when the primers have been developed with large number of data produced by DNA amplification and sequencing. Expressed sequence tags (ESTs) is another way to identify SNP which allow short sub-sequence of complementary DNA (cDNA) sequence. Because the double-stranded DNA is synthesized from a messenger RNA (mRNA), the generated sequences for SNP discovery may result in overlapping expressible sequences of another gene. This may result in low discovery rate of 15 to 50 % (Ganal et al., 2009).

Another way to search for SNP is by analyzing and hybridizing the candidate sequences using DNA probe array. This method is based on PCR amplification of specific oligonucleotides whose contain a relatively small number of nucleotides (Cargill et al., 1999) (Imelfort et al., 2009).

### 2.11.4 SNP Detection in CAPN1 Gene

The CAPN1 gene play an important role in the degradation of myofibrillar proteins and meat tenderization postmortem. The human CAPN1 gene has 22 exons spanning approximately 30kb (Figure 2.5).

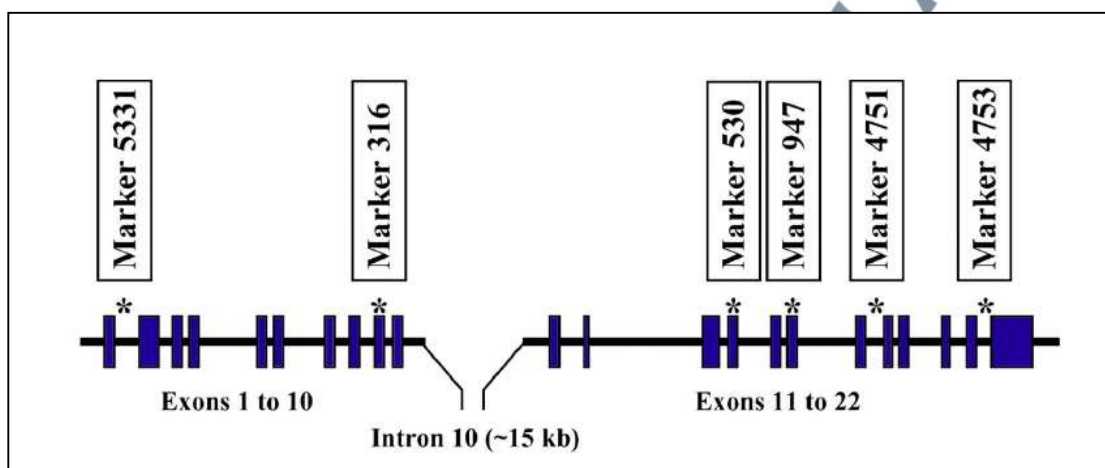

**Figure 2.5:** Organization of the CAPN1 gene and localization of SNP markers.

The SNP markers in the CAPN1 gene have been previously investigated for their association with meat quality and tenderness (Page et al., 2002; Okumura et al., 2006; Zhang et al., 2007a,b, 2008). Ropka-Molik et al. (2014) reported eight missense mutations in five exons of the CAPN1 gene as molecular markers for meat tenderness in pork. A year later the same authors discovered polymorphic sites in 3'UTR of the CAPN1 gene and their association with lean meat percentage.

In chickens, 4 polymorphisms, 3 synonymous single nucleotide polymorphisms (SNPs) (i.e., C2546T, G3535A, and C7198A), and one SNP within the 3'-UTR (G9950A) of the CAPN1 gene have been found to have significant effects on meat tenderness (Zhang et al., 2007a,b, 2008). Chinese scientists Zhang et al. (2008) and Shun et al. (2015) calculated the effect of CAPN1 on economically important chicken

traits. The mutations in the fifth and sixth exons are found to change fiber density, and that the C2546T / G3535A / C7198A haplotype affected live, carcass, breast and leg muscle weights. Moreover, a mutation within exon 4 are associated with pH in breast muscle and intramuscular fat content. Observation studies by Sun et al. (2013) and Felício et al. (2013) confirmed the effects of mutations in the CAPN1 gene with documented evaluations performed on different indigenous chicken breeds. However, there are no available publication that studied the association of these SNPs in Malaysian indigenous chickens.