

DESIGN OF A LOW-COST AUTOMATIC DISINFECTION CHAMBER

Hanis Izzuddinⁱ, Khairul Nabilah Zainul Ariffinⁱⁱ, Musab Sahrimⁱⁱ, Irneza Ismailⁱⁱ,
Shahnurriman Abdul Rahmanⁱⁱ, Liyana binti Ramliⁱⁱ & Mohammad Hamiruce Marhabanⁱⁱ

ⁱ (*Corresponding author*). Senior Lecturer, Department of Electrical and Electronic Engineering, Faculty of Engineering and Built Environment, Universiti Sains Islam Malaysia. nh.izzuddin@usim.edu.my

ⁱⁱ Senior Lecturer, Department of Electrical and Electronic Engineering, Faculty of Engineering and Built Environment, Universiti Sains Islam Malaysia

Abstract

This study aims to develop a disinfection chamber that is portable and equipped with an automatic disinfectant spray system. The automatic disinfection chamber works by implementing a mechatronics system design which involves the use of the sensor, controller, and actuator. Firstly, an ultrasonic sensor is used to detect the presence of a user at the entrance of the chamber. Then, a microcontroller that acts as a brain to the system processes the sensor reading and produces an electrical signal to activate the water pump (actuator). This allows the water pump to channel the disinfectant solution from the tank to the spray nozzle for the human disinfection procedure. The proposed disinfection chamber has several advantages including automatic operation with minimal human intervention, as well as a modular design for easy transportation and assembly.

Keywords: Disinfection chamber

INTRODUCTION

Coronavirus disease 2019 (COVID-19) is an illness caused by the newly discovered severe acute respiratory syndrome coronavirus 2 (SARS-CoV-2) [1]. The virus is a strain of coronavirus which is known to cause respiratory infections in humans. After the first case reported in the People's Republic of China in late December 2019, the World Health Organization (WHO) has declared this highly contagious disease as a global public health emergency on March 2020 [2]. Some of the symptoms of COVID-19 are dry cough, difficult breathing, high fever, and atypical pneumonia [3]. This illness can be confirmed via real-time reverse transcription polymerase chain reaction (rRT-PCR) and computed tomography (CT) scans of the patient's chest [4].

The SARS-CoV-2 virus can be transmitted from human-to-human primarily via respiratory droplets of the infected person, as well as contact with surfaces that have been contaminated with this virus [5], [6]. According to [7], SARS-CoV-2 can stay for

three hours in aerosols [7]. Based on this finding, major considerations need to be taken to prevent the spread of the virus by aerosols. Since there is no vaccine for COVID-19 is found yet, nonpharmaceutical interventions (NPI) which rely on preventing the spread of the virus by droplets and close contact of the contaminated surfaces may be the best available strategy to contain the pandemic and reduce the rate of infection, i.e. flattening the curve [8]. This can reduce the risk of overwhelming health facilities, allowing for improved care of existing patients and avoiding new cases until there are appropriate treatment or a vaccine available.

Precautionary steps to minimize the risk of SARS-CoV-2 infection include wearing a face mask in public, remaining at home, avoiding crowded areas, maintaining distance from others, and washing hands with soap and water regularly [9]. Currently, the WHO advises that people wear face masks if they have respiratory problems or are taking care of someone with COVID-19 symptoms [10]. Surgical masks and N95 masks are commonly used by the general public and health care workers. Although there is no evidence that the surgical mask can protect the user against SARS-CoV-2, it may slightly reduce the spread of the virus from the infected persons by arresting droplet transmission [11]. On the other hand, the N95 mask is more suitable for the usage of health-care workers which has direct contact with patients as it can filter smaller particles as compared to the surgical mask [12]. Another preventive measure taken by most countries to control the spread of COVID-19 is by controlling the movement of the people. This includes tight border control, quarantine, and testing of the travelers, and also social distancing [13]. Social distancing, also called “physical distancing” works by keeping a safe space between people who are not from the same household.

Apart from keeping a safe distance between people to avoid infection through the air, the disinfection of contaminated surfaces also play a major role in controlling and preventing the spread of COVID-19 as SARS-CoV-2 can persist on various surfaces from hours to days [7]. This is consistent with the recommendation by WHO that suggest correct and consistent disinfection and cleaning of the environment [5]. The disinfection can be carried out by several types of physical and chemical methods including UVC and biocidal agents [14]. UVC which has a wavelength of 200 nm to 280 nm is found useful for the disinfection of the virus. However, direct human exposure to UVC should be avoided as it is harmful to the eyes and skin [15]. On the other hand, biocidal agents such as hydrogen peroxide are also used worldwide as disinfectants for fogging in various public and private facilities [15]. An autonomous disinfection chamber was proposed by Maurya *et al.* [13] to tackle external surface disinfection on humans using disinfectant solution mist and UV light. The structure of the chamber was constructed from mild steel with a wooden plywood base. The authors in [13] claimed that the proposed processes may reduce the virus contamination on clothes, skin, and any other exposed body surface getting treated.

In this paper, a low-cost autonomous disinfection chamber system is proposed to help with the external disinfection of humans. The aim is to design and fabricate the chamber using low-cost materials that are light and portable with automatic functional capability. Instead of using mild steel as in [13], we propose the structural design of the chamber using PVC pipes which has a lower cost. The disinfectant solution mist is sprayed automatically when human is detected inside the chamber by integrating ultrasonic sensor, microcontroller, and water pump. Note that this study focuses on the design of the disinfection chamber system, while the effectiveness of such a method is not within the scope.

This paper is organized as follows. In the second section, the design of the chamber is provided. In the following section, the fabrication of the designed chamber is presented, followed by the controller design. Concluding remarks are given at the end of this paper.

METHODOLOGY

This study aims to develop a disinfection chamber that is portable and equipped with an automatic disinfectant spray system.

Figure 17 shows the overall diagram of the proposed automatic disinfection chamber. The automatic disinfection chamber is designed by implementing the mechatronics system approach which involves the integration of sensor, controller, actuator, and mechanical components.

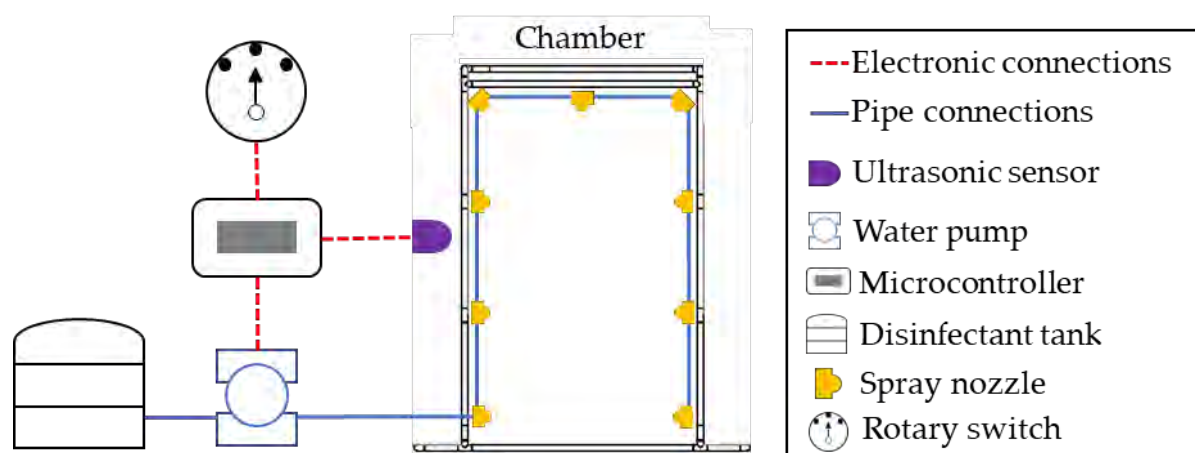

Figure 17 Diagram of the proposed automatic disinfection chamber.

Firstly, an ultrasonic sensor is used to detect the presence of a user at the entrance of the chamber. Then, a microcontroller processes the sensor reading and produces an electrical signal to activate the water pump (actuator). This allows the water pump to channel the disinfectant solution from the disinfectant tank to the

spray nozzle to allow the disinfection procedure in the chamber. The following subsections describe the design and development process of the automatic disinfection chamber system.

Structural Design of the Disinfection Chamber

This section discusses the design of the chamber's structure using computer-aided design (CAD). **Figure 18** shows the structure of the chamber from the front, side, and isometric view. This chamber is designed with a dimension of 1.25 m wide, 1.50 m length, and 2.00 m height by assembling the PVC pipes model in the CAD software.

In this study, PVC pipes are proposed as the mainframe structure of the chamber due to the low cost, high availability, and good rigidity of the material. Also, they allow the system to be modular and portable so that it can easily move and be assembled from one place to another.

Table 8 lists the items used for the fabrication of the frame structure for the chamber.

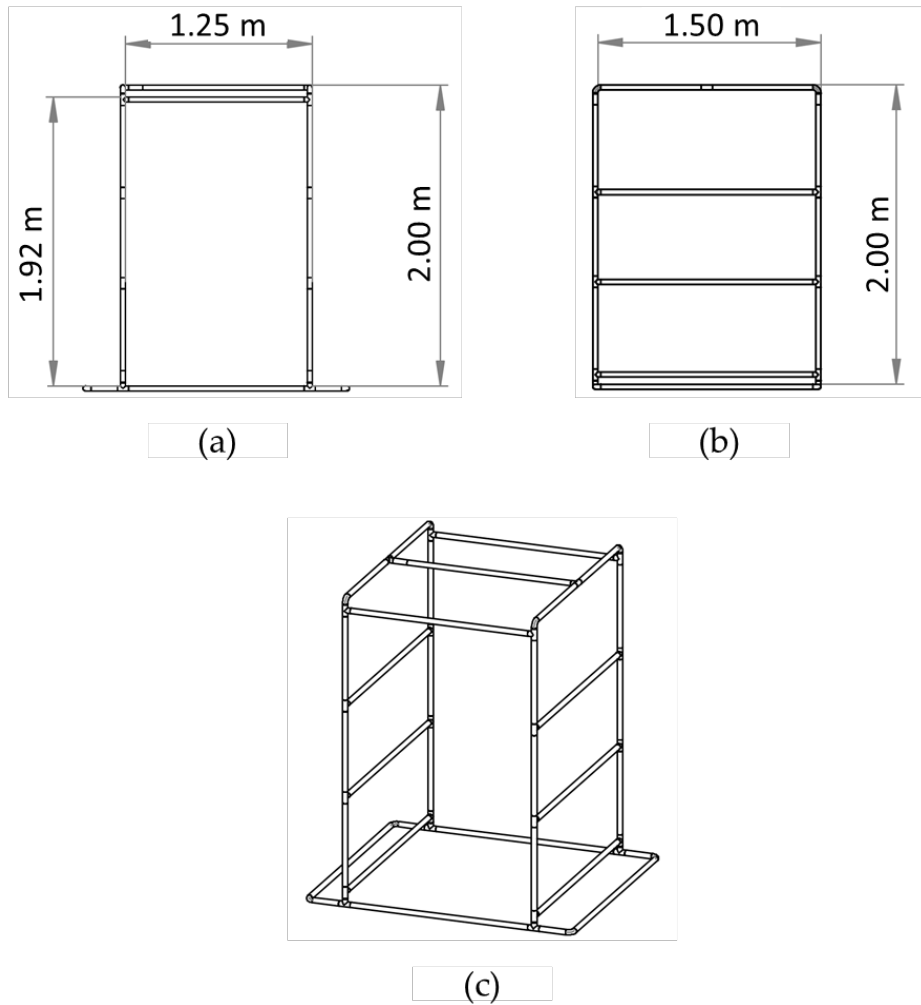

Figure 18 Structural design of the chamber using CAD software (a) front view (b) side view (c) isometric view.

From the disinfectant tank as shown in

Figure 17, the disinfectant solution is pumped to a series of spray nozzles creating mist for disinfecting the person inside the chamber. The spray nozzle may be placed at suitable places that improve the spray coverage. For example, a total of nine spray nozzle is used to create a mist with the arrangement illustrated in Figure 19.

Table 8 List of items used for fabrication of the chamber frame

No.	Item	Size	Quantity
1	PVC pipes	1 inch	30.25 m
2	PVC tees	1 inch	22
3	PVC elbow	1 inch	8

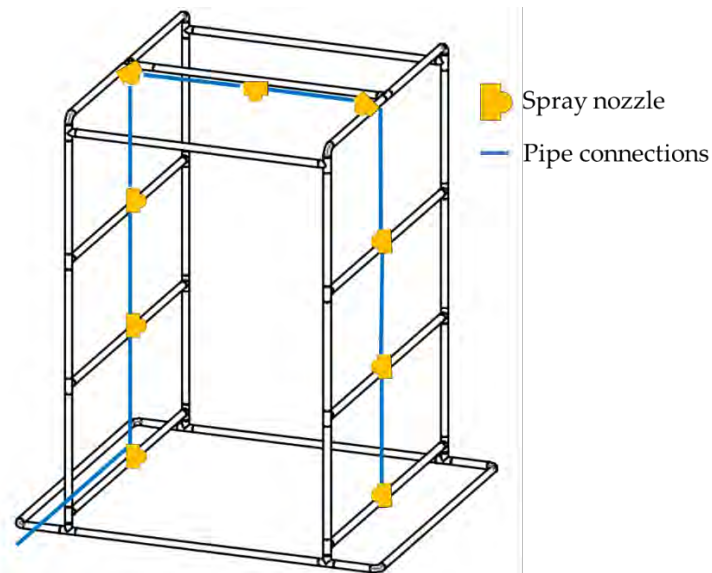

Figure 19 Position of the spray nozzles.

Controller Design

Figure 20 shows the diagram of the control system. It consists of a microcontroller that controls the operation of the disinfection system according to the user-written program, an ultrasonic sensor that detects the presence of a person in the chamber, a water pump as an actuator that transfers the disinfectant to the spray nozzle, and a rotary switch as input for operation modes. Also, the relay is used as an interface between the microcontroller and water pump that has 12V operational voltage.

There are two modes of operations for the disinfection chamber: automatic and manual mode. These modes can be selected by the user using a rotary switch. The operation modes are programmed into the microcontroller based on the flowchart in

Figure 21. Initially, the program parameters such as preset operation time and ports are initialized. Then, the rotary switch that corresponds to the operation mode is read. Based on the switch position, the microcontroller turns on/off the water pump that thrust the disinfectant to the nozzle to produce the mist inside the chamber. For the manual mode, the water pump continuously operates to produce mist in the chamber until turned off. On the other hand, the water pump only operates to produce mist when a user is detected in the chamber for the automatic mode. This makes the disinfection process more efficient without requiring a human operator, as well as saving the disinfectant solution and electricity.

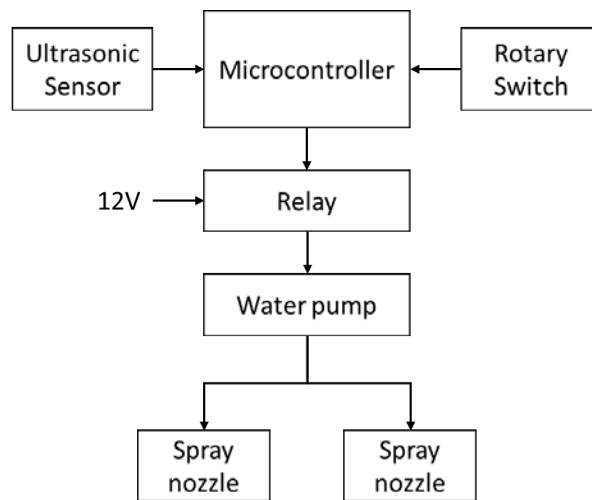

Figure 20 Diagram of the control system.

Integration of the Automatic Disinfection Chamber

The second phase of this work involves the fabrication of the low-cost disinfection chamber as shown in Figure 22 based on the structural design and controller design described in previous sections. The disinfection chamber structure is covered by a white waterproof canvas at the side and top. Meanwhile, transparent plastic curtains are installed at the entrance and exit of the chamber to reduce the effect of external wind towards the mist formation in the disinfection chamber. Also, the controller and sensor are placed at the entrance to detect the user entering the chamber for an automatic mode of operation. Overall, the disinfection chamber system is easy to be installed due to the modular nature, as well as lightweight due to material selection.

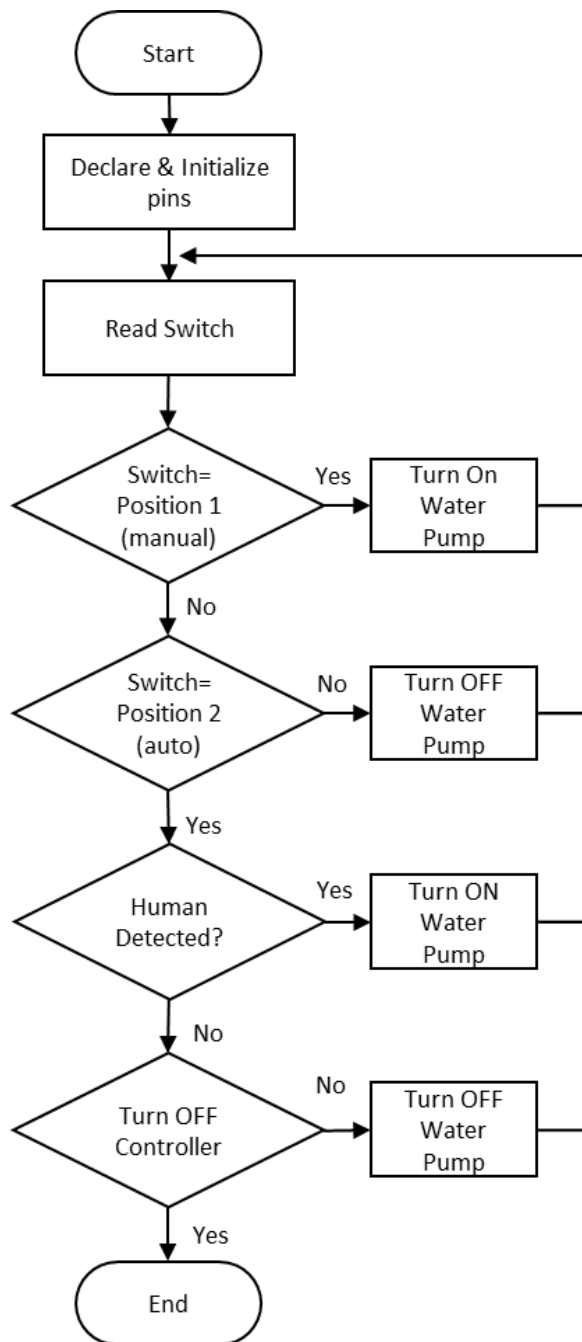

Figure 21 Flowchart of disinfection operation.



Figure 22 Fabricated low-cost automatic disinfection chamber.

CONCLUSION

This paper discusses the design and development of a low-cost disinfection chamber that is portable and equipped with an automatic disinfectant spray system. The mechatronics design approach is used for system development which involves the integration of sensors, controller, actuator, and mechanical components. Firstly, the disinfection chamber structure is designed using computer-aided design software. Then, the controller for the spray system is developed which allows automatic operation of the disinfectant spray when users detected. Finally, these subsystems are integrated and fabricated to form an automatic disinfection chamber. Future works may involve the effectiveness study of the disinfection chamber.

ACKNOWLEDGEMENT

This research is supported by Universiti Sains Islam Malaysia (USIM) through USIM COVID-19 Research Grant No. PPPI/COVID-19_0120/FKAB/051000/10620.

REFERENCES

- [1] H. Science, "Harnessing Science, Technology and Innovation in India for Tackling COVID-19," no. April, pp. 1–35, 2020.
- [2] L. Wang, Y. Wang, D. Ye, and Q. Liu, "A review of the 2019 Novel Coronavirus

- (COVID-19) based on current evidence," *Int. J. Antimicrob. Agents*, p. 105948, 2020.
- [3] N. Zhu *et al.*, "A novel coronavirus from patients with pneumonia in China, 2019," *N. Engl. J. Med.*, 2020.
 - [4] T. Ai *et al.*, "Correlation of chest CT and RT-PCR testing in coronavirus disease 2019 (COVID-19) in China: a report of 1014 cases," *Radiology*, p. 200642, 2020.
 - [5] H. Fathizadeh *et al.*, "Protection and disinfection policies against SARS-CoV-2 (COVID-19)," *Infez Med*, vol. 28, no. 2, pp. 185–191, 2020.
 - [6] J. F.-W. Chan *et al.*, "A familial cluster of pneumonia associated with the 2019 novel coronavirus indicating person-to-person transmission: a study of a family cluster," *Lancet*, vol. 395, no. 10223, pp. 514–523, 2020.
 - [7] N. Van Doremalen *et al.*, "Aerosol and surface stability of SARS-CoV-2 as compared with SARS-CoV-1," *N. Engl. J. Med.*, vol. 382, no. 16, pp. 1564–1567, 2020.
 - [8] S. Gössling, D. Scott, and C. M. Hall, "Pandemics, tourism and global change: a rapid assessment of COVID-19," *J. Sustain. Tour.*, vol. 0, no. 0, pp. 1–20, 2020.
 - [9] N.-C. Chiu *et al.*, "Impact of wearing masks, hand hygiene, and social distancing on influenza, enterovirus, and all-cause pneumonia during the coronavirus pandemic: Retrospective national epidemiological surveillance study," *J. Med. Internet Res.*, vol. 22, no. 8, p. e21257, 2020.
 - [10] S. Feng, C. Shen, N. Xia, W. Song, M. Fan, and B. J. Cowling, "Rational use of face masks in the COVID-19 pandemic," *Lancet Respir. Med.*, vol. 8, no. 5, pp. 434–436, 2020.
 - [11] A. Agrawal and S. G. Singh, "PREFACE on the Special Issue 'Technologies for Fighting COVID-19,'" *Trans. Indian Natl. Acad. Eng.*, vol. 5, no. 2, pp. 91–95, 2020.
 - [12] Y. Xiao and M. E. Torok, "Taking the right measures to control COVID-19," *Lancet Infect. Dis.*, vol. 20, no. 5, pp. 523–524, 2020.
 - [13] D. Maurya *et al.*, "Development of Autonomous Advanced Disinfection Tunnel to Tackle External Surface Disinfection of COVID-19 Virus in Public Places," *Trans. Indian Natl. Acad. Eng.*, vol. 5, no. 2, pp. 281–287, 2020.
 - [14] B. V Sarada, R. Vijay, R. Johnson, T. N. Rao, and G. Padmanabham, "Fight against COVID-19: ARCI's technologies for disinfection," *Trans. Indian Natl. Acad. Eng.*, vol. 5, no. 2, pp. 349–354, 2020.
 - [15] C. P. Sabino *et al.*, "Light-based technologies for management of COVID-19 pandemic crisis," *J. Photochem. Photobiol. B Biol.*, p. 111999, 2020.
 - [16] G. Kampf, D. Todt, S. Pfaender, and E. Steinmann, "Persistence of coronaviruses on inanimate surfaces and their inactivation with biocidal agents," *J. Hosp. Infect.*, vol. 104, no. 3, pp. 246–251, 2020.