

# CORPORATE *WAQF* AS AN INSTRUMENT FOR SUSTAINABILITY OF ECONOMIC WELL-BEING

Nurul Adilah Hasbullah<sup>1</sup>  
Khairil Faizal Khairi<sup>2</sup>

## ABSTRACT

*Waqf* is a one of the instrument for the poverty alleviation among the community because it can encourage the development of economic well-being. If the economic well-being of people can reach, thus there is no gap between the rich and poor. In order to ensure that the *waqf* system line with the modernization nowadays, then corporate *waqf* was introduced. Johor Corporation Berhad (JCorp) is an innovator of this corporate *waqf* which bring the great changes to the *waqf* system as a whole. The objective of this article is to identify the uniqueness of the corporate *waqf* and to investigate the contribution of this type of *waqf* towards economic well-being of the people. The methodology of this article is a quantitative research based on the document analysis of relevant references. The general finding of this article shows that the proper implementation of corporate *waqf* is very useful in developing the economic well-being of the people.

**Keywords:** Corporate *Waqf*, Economic Well-Being.

## 1. INTRODUCTION

Economic activities are very important to bring people to away of life organized. However, the economic system adopted today is the capitalist system which often occur tyranny, usury, fraud, corruption, disproportionate monopoly, market manipulation and so on. Therefore, many in our society oppressed and still plagued by poverty and misery of life and this condition is called as the poor become poorer and the rich become richer. If not take any action to solve this problem, of course, the fate of the poor are not neglected and the rich looked more rampant. In order to combat this problem, charity is a one of the potential ways because it can be in many forms. But, the only charity in a long lasting form is *waqf* because it has the element of perpetuity.

The *waqf* or charitable endowments is one of the important institutions in preventing poverty among the community and generating economic well-being of people because it is a fund that cannot be forfeited or lost and must be managed by the trust. It also cannot be traded for the sake of greed and desire to unrestricted money. Thus, it become perpetual property in the interest of the people all the time. If the economic well-being of the people can be established, absolutely there is no gap between the rich and poor and everyone is in the same level of life. The important of *waqf* is similar to *infaq*, *sadaqah jariyah* and *hibah* (Abd. Shakor, 2011) and it is a vital instrument in helping the public.

---

<sup>1</sup> Postgraduate Student, Faculty of Economics and Muamalat, Universiti Sains Islam Malaysia, Bandar Baru Nilai, 71800 Nilai, Negeri Sembilan, Malaysia. Corresponding author: n.adilahasbullah@gmail.com.

<sup>2</sup> Senior Lecturer, Faculty of Economics and Muamalat, Universiti Sains Islam Malaysia, Bandar Baru Nilai, 71800 Nilai, Negeri Sembilan, Malaysia.

Through *al-Quran* or *al-hadith*, we cannot found the exact meaning of the *waqf*. It function same as *infaq*, *sadaqah jariyah*, *hibah* and so on. The *fuqaha* defines the *sadaqah jariyah* as a giving some property in his or her life and its usage everlasting (Abd. Shakor, 2011). From literally, the word *waqf* derived from Arabic word *waqafa* that means restrain (*al-habs*) or forbid (*al-man*) (Siti Mashitoh, 2007).

Based on the *jumhur ulama'* views, the *waqf* in legally means to restrain a property that can gain the benefits from it, its physical is perpetual and not becoming the property of a third party (Nurul Asyikin and Muhammad Hakimi, 2013). Based on the definition above, we can understand that once a person donated his or her property as *waqf*, then he or she not have any ownership on that donated property anymore instead will become Allah belongings forever and it can never be transact. At the same time, the public will earn the benefits from that donated property without any certain period.

As mentioned earlier, *waqf* had no definite meaning in the *al-Quran* and *al-hadith*. But, the existence of *waqf* in Islam based on three foundations (Dahlia & Haslindar, 2013):

First, The Prophet (p.b.u.h) mentioned as reported in a *hadith*: *Whence a child of Adam dies, his or her deed comes to an end except for three things; running and continuous sadaqah, knowledge that benefits (others) and a righteous child who pray for him or her.* (Hadith reported by Muslim, Tarmidhi, Abu Dawud, Nasa'i and Ibn Majah).

Second, Umar bin al-Khattab, as reported by Ibn Umar, went to the Prophet (p.b.u.h) and said "*Messenger of Allah! I got a land in Khaibar. I never got a property more precious to me than this. What do you advise me?*" The Prophet (p.b.u.h) said, "*If you want you can make habs on (bequeath) it, and give it as sadaqah (charity); provided that it should not be sold, bought, given as a gift or inherited*". Then Umar gave it as charity for the poor, relatives, slaves, wayfarers and guests. There is no harm for the person responsible for it to feed himself or a friend from it for free, without profiting.

Third, All the Prophet's (p.b.u.h) companions proclaimed their lands as *waqf*. This evidenced through narrations and report by Thabit bin Anas Jabir bin Abdullah and Ibn Hazm.

This article will explore the concept of corporate *waqf* and how Johor Corporation Berhad (JCorp) implemented it in Section 2. The research methodology of this article will be exposing in Section 3. While, the result and conclusion of this study will be explain in Section 4 and 5 respectively.

## **2. LITERATURE REVIEW**

### **2.1 Concept of Corporate Waqf**

The *waqf* practice today is differ from the traditional one because it follows the requirement nowadays and parallel with the modernization. One of the *waqf* innovations that attract the world's attention is corporate *waqf* that was introduced by Johor Corporation Berhad (JCorp). The uniqueness of this corporate *waqf* is the share as a main fund in contributing to the *waqf*. From the law perspective, *waqf* in form of share is permissible in *Shariah* since it is in line with the principles and concept of *waqf* in Islam (Abd. Shakor, 2011).

Nurul Asykin and Muhammad Hakimi (2013), literally, the word share derived from the Arabic word *sahama* that means portion and from the legally, the word share have many meanings for example if refer to the Kamus Dewan, the word share means portion in a business capital. If refer to the Kamus Pelaburan Saham, the word share means security of the ownership in a company. While in the Buku Glosari Pasaran Modal and Glosari Pasaran Modal Islam, the share is ownership importance unit in equity security.

Corporate *waqf* is an innovative mechanism in generating income for the benefits of most society in the form of cash *waqf*, *waqf* share and other assets investment methods (Dahlia and Haslindar, 2013). The same authors also mentioned that the corporate *waqf* is an initiative in combining perpetuity characteristic of *waqf* to achieve the power of entrepreneurial dynamism. Based on Norma, Salina and Zarinah (2013), corporate *waqf* is an idea combining corporate efforts with the aim of giving back to the society through *waqf* concept. They added that the corporate *waqf* is an innovation with the intention to revitalize the once powerful *waqf* institution and benefitting from its dynamics towards adding value and producing wealth through business and corporate efforts to encourage economic growth.

According to Nurul Asykin and Muhammad Hakimi (2013), during ‘Seminar Awqaf Antarabangsa 2008’, Prof. Murad Cizakca said that the corporate *waqf* management is a most sophisticated in Islamic financial practice nowadays. The existence of corporate *waqf* shows the big success of *waqf* system because the money collected through share can be use for many economic development projects without having any restrictions or obstacles same as *waqf* of immovable property (Asmak, 2009).

## **2.2 Corporate Waqf of Johor Corporation Berhad (JCorp)**

### *i. Waqaf An-Nur Corporation Berhad (WANCorp) as a Mutawalli*

Waqaf An-Nur Corporation Berhad (WANCorp) is a one of its subsidiary company was entrusted to manage all JCorp groups’ assets and shares that are donated as *waqf* (Dahlia and Haslindar, 2013). On 25 October 2000, WANCorp start its operation by using name of ‘Pengurusan Klinik Waqaf An-Nur’ (Abd. Shakor, 2011). After memorandum of understanding (MOU) was made between JCorp and State Islamic Religious Council of Johor (SIRCJ) on 4 December 2009, SIRCJ agreed to appoint WANCorp to act as a special *mutawalli* in orderto manage shares and assets which have been made *waqf* assets by JCorp and transferred to WANCorp (Norma, Salina and Zarinah, 2013). It is follows the Waqf Procedures 1983 under the Enactment of Islamic Administration Johor 2003 (Dahlia and Haslindar, 2013).

Nurul Asykin and Muhammad Hakimi (2013), the objective of the establishment of WANCorp consists of management and administration based on the Islamic values, planning and coordinating religious activities and roles as mosque committee secretariat and coordinating the management of that mosque. WANCorp also run the research that used contemporary approach, next, suggest the project implementation that suitable with the JCorp’s vision and struggle to be references hub in matters related business management in Islamic.

ii. *Six Subsidiaries of JCorp are al-Waqif*

Six subsidiaries of JCorp are *al-waqif* in the corporate *waqf* practice. Annual Report WANCorp 2012, three of it is Listed Companies and the three left is Unlisted Companies. The Public Listed Companies are KPJ Healthcare Berhad, Kulim (M) Berhad and Al-‘Aqar KPJ Reit. The Unlisted Companies are Tiram Travel Sdn Bhd, Larkin Sentral Property Sdn Bhd and Capaian Aspirasi Sdn Bhd.

Based on the Annual Report WANCorp 2012, the JCorps’ share donated as *waqf* as Table 1 below. KPJ Healthcare Berhad was donated 14.38% (18.6 millions of share, Kulim (M) Berhad was donated 3.85% (12.35 millions of share), Al-‘Aqar KPJ Reit was donated 1.81% (12.62 millions of share), Tiram Travel Sdn Bhd was donated 75% (225 thousands of share), Larkin Sentral Property Sdn Bhd was donated 61% (50.33 thousands of share) and Capaian Aspirasi Sdn Bhd was donated 75% (75 thousands of share).

Based on the Annual Report WANCorp 2012 also, the financial performance of WANCorp in 2012 was keep growth caused of the strength national economic condition which contributes towards increasing in the performance of the *waqf* share. The dividend earned in 2012 from the *waqf* share is increasing dramatically which about RM57.56 millions compared to just RM16.94 millions in 2011. In order to know about the performance of those companies, please refer Table 2 and 3 below.

iii. *Distribution of the Dividend Earned*

Refer to Figure 1 bellows, the productivity’s concept of the corporate *waqf* can be seen through the benefits of the property as an input that consists of annual dividend of the share from six subsidiaries of JCorp, contribution of cash *waqf* by WANCorp as a membership participation and 70% of dividend of the reinvestment. The total of the benefits will be collect and distribute to the three groups with different percentage of the distribution which based on the *hujjah waqf* that agreed 70%, 25% and 5%. The benefit’s distribution as called as production process and welfare programmes and Islamic Corporate Social Responsibility (ICSR) as an output of this kind of *waqf* concept.

The 70% of the dividend earned goes back to JCorp for reinvestment and human capital development, 25% goes to WANCorp for *Fisabilillah* and 5% goes to SIRCJ. Until 31 December 2012, the 70% of fund for reinvestment is about RM36.27 millions and invested as fix savings in financial institutions which based on the *Shariah*. The income earned from the investment in 2012 is about RM421,418.71. The total income earned from the investment until 31 December 2012 is about RM1,017,696.86.

Based on the Annual Report WANCorp 2012, 60% (RM2,088,117) of fund from *Fisabilillah* used for charity and social works such as sick patient’s treatment, mosques management and other Corporate Social Responsibility Programme, 38% (RM1,312,303) used for human capital development such as ‘Tabung Akedemi Mutawwif’ and 2% (RM60,000) used for special project such as ‘Program Kemantapan Orang Asli Johor’. The amount from 5% goes to SIRCJ is about RM2,861,700 in 2012.

### 3. RESEARCH METHODOLOGY

This study focusing on the corporate *waqf*'s implementation that practiced by the JCorp. This institution was selected since it is first ever implemented of corporate *waqf* in Malaysia. In terms of collecting data and information, this study used secondary data as main resources. According to Saunders, Lewis and Thornhill (2009), secondary data can be defined as data used for a research project that were originally collected for some other purpose. Thus in this study obtained the information through the accessed the website of JCorp and WANCorp, annual report of both institutions as well as through the other researchers journals.

### 4. RESULT

Corporate *waqf* implemented by JCorp is able to give the benefits for many parties. Firstly, for the government, the *waqf* is a one of the instruments to redistribute the wealth due to reach economic development entirely. This is because *waqf* plays an important role that is significant in providing education, economic and infrastructure. Indirectly, the government will able to reduce the expenditure which leads to a reduction in the budget deficit. In addition, through *waqf* also, the government's need in borrowing will be low which leads to a reduction of the interest rate that curbing the growth of the country.

Secondly, for the company, besides they can fulfil the Islamic Corporate Social Responsibility (ICSR), they also can gain the long-lasting benefit if they are practice the corporate *waqf*. Besides help the needy, they also can ensure that the equity ownership is belongs to Malaysian Muslims. Thus, it can bring the potential growth and addition of equity for public benefits. The equity growth will be gained through revenue from the investment of some *waqf* property in the form of share. The equity here means the share and securities of the companies.

Lastly, for the community, the *waqf* can provide them a lot of the benefits. Those are benefits covered the aspects of education, economic, health, and infrastructure. For education, the *waqf* can provide scholarship or training that will improve the quality of the community by enhancing their knowledge and skills. In the end, the community will able to get a job or set up a business.

For the economic, the *waqf* can provide business premise and centre and financing assistance based on the *qardhul hassan*. Through the business premise and centre that developed from the *waqf* fund or land, it adds the potential to run the business activities among the community. From the financing assistance which based on the *qardhul hassan*, the person or group which lack of the financial capital will able to set up and run the business and they will not burden by highest interest of loans. Thus, it can reduce unemployment problem in our country.

Last but not least, the community also can gain the infrastructure benefit through *waqf* practice such as school, medical facilities, place of worship, and so forth which will help in improving the community's welfare. *Waqf* is an important institution for environment protection and social living improvement by providing transportation facilities such as road and bridge, and municipality, agriculture and development such as school and hospital. All those benefits, thus, no terms of the poor become poorer and the rich become richer anymore among community.

## 5. CONCLUSION

As a conclusion, corporate *waqf* is very applicable nowadays because it line with the modernization. Since share as a main fund in contributing into the *waqf*, thus the community are capable to practice it. The corporate *waqf* can provides a lot of the contribution in preventing economic problems among the community due to the dividend earned from the this type of *waqf* can fulfil the people's need entirely. As a evidence, the corporate *waqf* that was implemented by JCorp is successful in helping community because 25% allocated for *Fisabilillah* from the dividend earned used for the various activities such as charity and social works, human capital development and special project. As a result, the corporate *waqf* can contribute towards economic development, equal distribution among the community and respond against Vision 2020.

## REFERENCES

- Abd. Shakor bin Borham. (2011). Pelaksanaan Pembangunan Wakaf Korporat Johor Corporation Berhad (JCorp): Satu Tinjauan. *International Conference on Humanities 2011*.
- Annual Report WANCorp 2011.
- Annual Report WANCorp 2012.
- Asmak Ab Rahman. (2009). Peranan Wakaf dalam Pembangunan Ekonomi Umat Islam dan Aplikasinya di Malaysia. *Jurnal Syariah, Jil. 17, Bil. 1 (2009) 113-152*.
- Dahlia binti Ibrahim and Haslindar binti Ibrahim. (2013). Revitalization of Islamic Trust Institutions through Corporate Waqf. *4<sup>th</sup> International Conference on Business and Economic Research (4<sup>th</sup> ICBER 2013) Proceeding*.
- Mark Saunders, Philip Lewis and Thornhill. (2009). *Research Methods for Business Students*. 5<sup>th</sup> Ed. Prentice Hall: Italy.
- Monzer Kahf and Siti Mashitoh Mahamood. (2011), *Essential Readings in Contemporary Waqf Issues*. Selangor: CERT Publications.
- Muhammad Ridhwan Ab. Aziz. (2012), *Introduction to Islamic Institutions in Economics and Finance*. Negeri Sembilan: USIM Publisher.
- Norma Md Saad, Salina Kassim and Zarinah Hamid. (2013). Involvement of Corporate Entities in Waqaf Management: Experiences of Malaysia and Singapore. *Asian Economics and Financial Review, 2013, 3 (6): 736-748*.







Nurul Asykin Mahmood and Muhammad Hakimi Mohd Shafiai. (2013). Potensi Wakaf Korporat kepada Pemilikan Ekuiti Muslim: Kajian di Wakaf An-Nur Corporation. *Prosiding Persidangan Kebangsaan Ekonomi Malaysia Ke VIII 2013*.

Siti Mashitoh Mahamood. (2006). *Waqf in Malaysia: Legal and Administrative Perspectives*. Kuala Lumpur: University of Malaya Press.

Siti Mashitoh Mahamood. (2007). Pembentukan Dana Wakaf Menurut Perspektif Syariah dan Undang-undang serta Aplikasinya di Malaysia. *Jurnal Syariah*, 15: 2 [2007] 61-83.

## APPENDIX

Table 1: Waqf Share of JCorp's subsidiaries

Listed Companies	
Kulim (M) Berhad 	3.85% (12.35 Millions of Share)
KPJ Healthcare Berhad 	14.38% (18.6 Millions of Share)
Al-‘Aqar KPJ Reit 	1.81% (12.62 Millions of Share)
Unlisted Companies	
Tiram Travel Sdn Bhd 	75% (225 Thousands of Share)
Capaian Aspirasi Sdn Bhd  CAPAIAN ASPIRASI	75% (75 Thousands of Share)
Larkin Sentral Property Sdn Bhd 	61% (50.33 Thousands of Share)

Source: Annual Report WANCorp 2012

Table 2: The Performance of Listed Companies

Company	Unit of Waqf Share (Millions of Unit)	Net Asset Value in the Beginning of Waqf (RM Millions)	Market Value in the Beginning of Waqf (RM Millions)	Net Asset Value in 31 Dec 2011 (RM Million)	Market Value in 31 Dec 2011 (RM Millions)	Net Asset Value in 31 Dec 201 (RM Millions)	Market Value in 31 Dec 201 (RM Millions)
Kulim (M) Berhad	12.35	142.00	51.61	270.66	208.43	204.97	242.02
KPJ Healthcare Berhad	18.60	45.00	34.03	78.56	218.49	158.99	266.84
Al-‘Aqar KPJ Reit	12.62	13.00	-	14.13	14.51	14.52	16.28
<b>Total</b>		<b>200.00</b>	<b>85.64</b>	<b>363.35</b>	<b>441.43</b>	<b>378.48</b>	<b>525.14</b>

Source: Annual Report WANCorp 2012

Table 3: The Performance of Unlisted Companies

Company	Unit of Waqf Share (Millions of Unit)	Net Asset Value in the Beginning of Waqf (RM Millions)	Net Asset Value in 31 Dec 2011 (RM Millions)	Net Asset Value in 31 Dec 2012 (RM Millions)
Tiram Travel Sdn Bhd	0.23	0.26	1.75	2.32
Capaian Aspirasi Sdn Bhd	0.08	0.01	0.45	0.48
Larkin Sentral Property Sdn Bhd	50.33	50.00	60.39	63.41
<b>Total</b>		<b>50.27</b>	<b>62.59</b>	<b>66.21</b>

Source: Annual Report WANCorp 2012

Figure 1: The Concept of Corporate Waqf

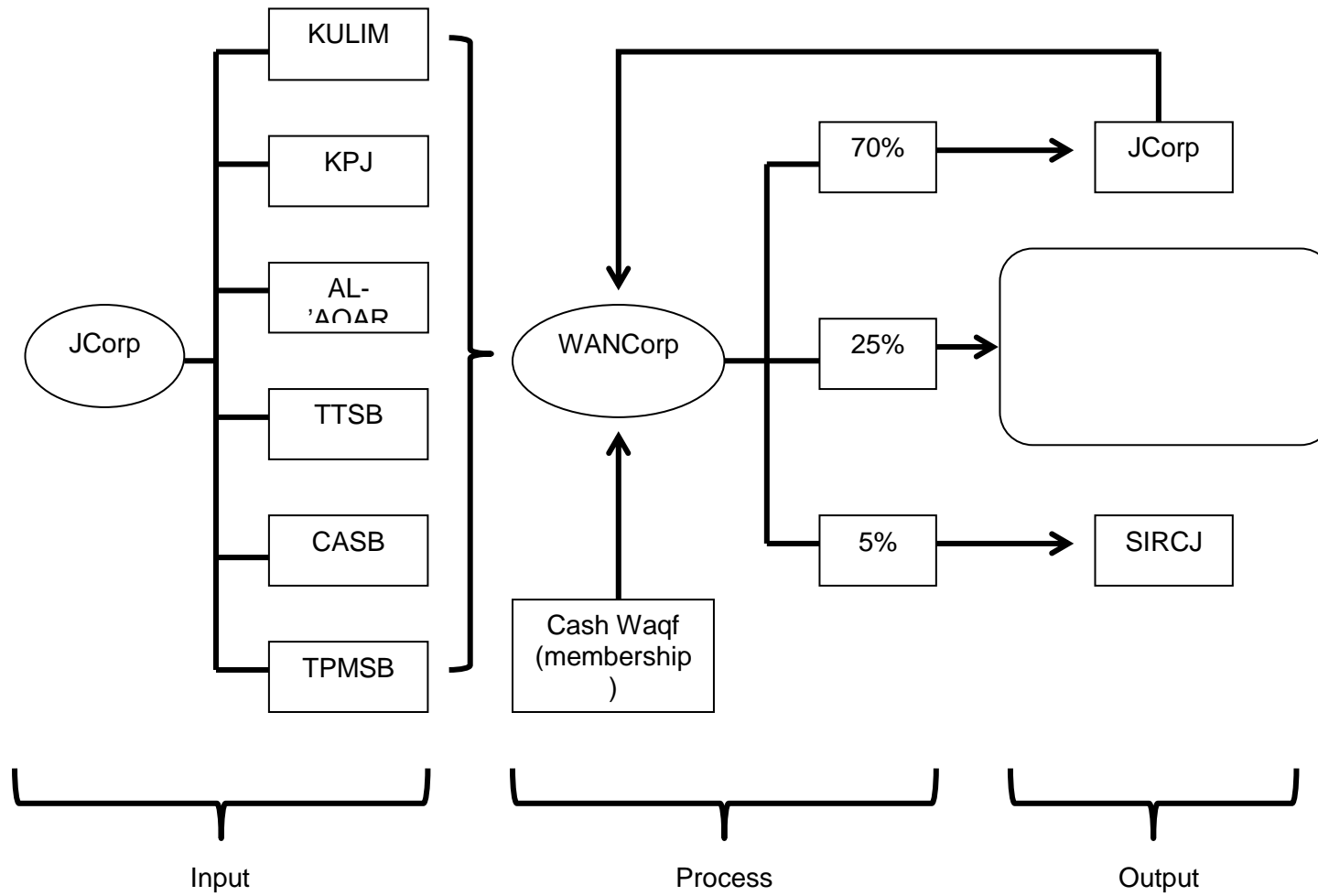

Source: Nurul Asyikin and Muhammad Hakimi, 2013